

nexen[®]

AIR CHAMP[®] PRODUCTS

User Manual



Models DPC-9T and DPC-11T

In accordance with Nexen's established policy of constant product improvement, the specifications contained in this manual are subject to change without notice. Technical data listed in this manual are based on the latest information available at the time of printing and are also subject to change without notice.

Technical Support:
800-843-7445
(651) 484-5900

www.nexengroup.com



WARNING

Read this manual carefully before installation and operation.

Follow Nexen's instructions and integrate this unit into your system with care.

This unit should be installed, operated and maintained by qualified personnel **ONLY**.

Improper installation can damage your system or cause injury or death.

Comply with all applicable codes.

Nexen Group, Inc.
560 Oak Grove Parkway
Vadnais Heights, Minnesota 55127

TABLE OF CONTENTS

Introduction ----- 1

Installation ----- 2

Air Connections ----- 4

Lubrication ----- 6

Operation ----- 6

Parts Replacement ----- 7

Replacement Parts ----- 9

Accessories ----- 10

Warranties ----- 11

INTRODUCTION

Read this manual carefully, making full use of its explanations and instructions. The "Know How" of safe, continuous, trouble-free operation depends on the degree of your understanding of the system and your willingness to keep all components in proper operating condition. Pay particular attention to all NOTES, CAUTIONS, and WARNINGS to avoid the risk of personal injury or property damage. It is important to understand that these NOTES, CAUTIONS, and WARNINGS are not exhaustive. Nexen cannot possibly know or evaluate all conceivable methods in which service may be performed, or the possible hazardous consequences of each method. Accordingly, anyone who uses a procedure that is not recommended by Nexen must first satisfy themselves that neither their safety or the safety of the product will be jeopardized by the service method selected.

Nexen's "DPC" (*Dual Friction Plate*) Clutches are designed to mount on shaft ends, or through shafts using a customer supplied Q.D. (*Quick Detachable*) Bushing. The dual friction plate design eliminates thrust loading of bearings when the "DPC" Clutch is connected to a bearing supported Flywheel, Sprocket, or Sheave.

Five components are combined to install Nexen's "DPC" Clutch, and a Pilot Mount Clutch, or as a Sheave Clutch.

The five basic components (each sold separately) are: Pilot Clutch Assembly, Sheave, Rotary Air Union Cap, Q. D. Bushing, and Rotary Air Union.

The inner and outer assemblies of the "DPC" Clutch rotate independently.

When mounted on a through shaft, the outer clutch assembly rotates, and upon engagement, the inner clutch assembly becomes the driven unit.

When mounted on a continually running shaft, the inner clutch assembly rotates, and upon engagement, the outer clutch assembly becomes the driven member.

Nexen recommends mounting the "DPC" Clutch with the outer clutch assembly rotating continuously; taking advantage of the cooling effect of the fins to dissipate heat generated when the clutch is engaged.



WARNING

This unit has rotating parts. A guard that will not restrict the flow of cooling air around the unit must be used if the unit is installed in an area where injury to an operator could occur.

INSTALLATION

NOTE: All "DPC" Clutch installations require a Q.D. (Quick Detachable) Bushing. Refer to Table 1 for Q. D. Bushing Specifications.

TABLE 1
Q.D. Bushing Specifications

MODEL	BUSHING TYPE	BORE	PULL-UP BOLT TIGHTENING TORQUE
DPC-9T	SK	2.375	15 ft. lbs.
DPC-1-1T	SF	2.875	30 ft. lbs.

SUPPORT BUSHING

NOTE: The Support Bushing provides radial load support at the shaft, and is used when bore sizes smaller than standard are required.

1. Place "DPC" Clutch, Friction Disc side down, and support large end of Splined Hub (Item 1) (See Fig. 1).
2. Insert Support Bushing into bore of Splined Hub (Item 1) (See Fig. 1).
3. Apply even pressure around the entire diameter of the Support Bushing, and press the Support Bushing into the Splined Hub (Item 1) (See Fig. 1).

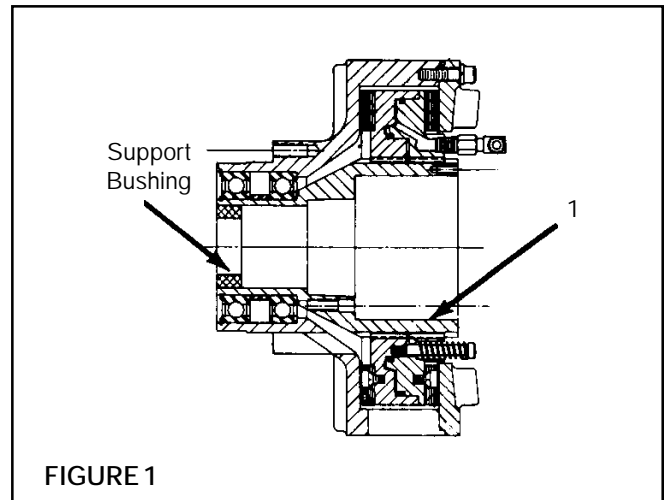

FIGURE 1

CAUTION

Do not use a hammer to install Support Bushing. Nexen recommends a small arbor press.

NOTE: On "DPC-9T" the Support Bushing fits flush with the end of the Splined Hub.

PILOT MOUNT CLUTCH

1. Install Support Bushing if required.
2. Thoroughly inspect tapered bore of the Splined Hub and tapered surface of the Q. D. Bushing. Remove any dirt, grease, or foreign material (See Fig. 2).

NOTE: Do not use lubricants when installing the Q. D. Bushing.

3. Install Q. D. Bushing into Splined Hub, aligning untapped holes on Q. D. Bushing Flange with tapped holes in Splined Hub (See Fig. 2).

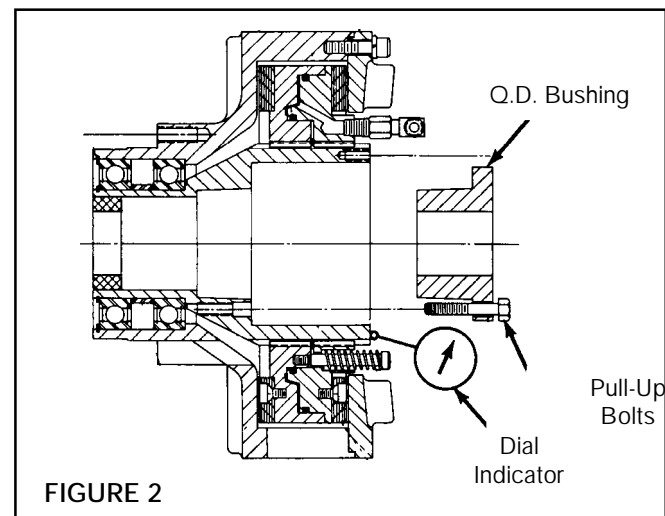

FIGURE 2

CAUTION

Do not strike Q. D. Bushing to "SET" it in the tapered bore.

4. Loosely insert Pull-Up Bolts and Lockwashers into Q. D. Bushing, and tapped holes of Splined Hub (See Fig. 2).

NOTE: Do not use lubricants or thread locking compounds on Pull-Up Bolts.

5. Measure runout of Motor Shaft. Runout must not exceed 0.002 T.I.R. (Total Indicator Reading) (See Fig. 2).
6. Insert Key into Motor Shaft Keyway.
7. Slide "DPC" Clutch onto Motor Shaft.
8. Alternately, and evenly tighten Pull-Up Bolts to recommended torque (See Table 1).

CAUTION

Do not over tighten Pull-Up Bolts. If excessive tightening torque is applied, bursting pressure is created in the Splined Hub.

NOTE: Runout is minimized if a Dial Indicator is used as the Q. D. Bushing Pull-Up Bolts are tightened. Place contact tip of Dial Indicator on the machined surface of the Splined Hub to measure runout. Runout on this surface must be within 0.003 T.I.R. when the Pull-Up Bolts are tightened (See Fig. 2).

SHEAVE MOUNT

NOTE: The Sheave Clutch is a combination of the Pilot Clutch and Sheave Assembly (both shipped in a separate container).

1. Slide the Sheave (Item 26) onto the pilot diameter of the Pilot Clutch Assembly (See Fig. 3).
2. Align the mounting holes in the Sheave (Item 26) with the tapped holes in the Housing (Item 5) (See Fig. 3).
3. Install the Cap Screws (Item 28), and Lockwashers (Item 27) (See Fig. 3).
4. Tighten the Cap Screws (Item 28) to the recommended torque (See Table 2).
5. Proceed with Steps 1 through 8 for Pilot Mount Clutch Installation.

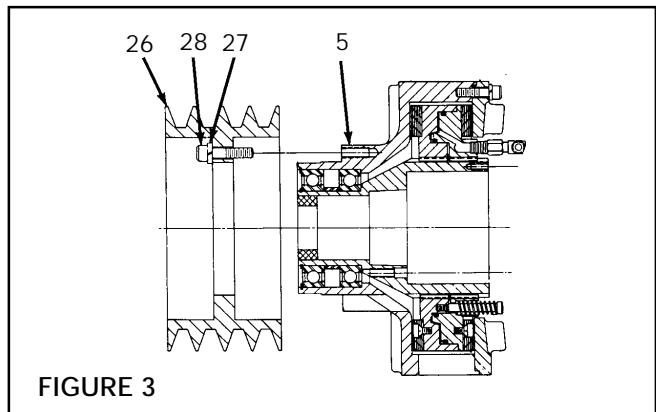

TABLE 2
Recommended Tightening Torques

DESCRIPTION	DPC-9T	DPC-11T
Shoulder Screw (Item 12)	9 ft. lbs.	9 ft. lbs.
Cap Screw (Item 15)	48 ft. lbs.	48 ft. lbs.
Cap Screw (Item 24)	13 ft. lbs.	13 ft. lbs.
Cap Screw (Item 28)	48 ft. lbs.	48 ft. lbs.

AIR CONNECTIONS

SHAFT END MOUNTING.

1. Install two Elbow Fittings (Item 20) into the Rotary Air Union Cap (Item 25) (See Fig. 4).
2. Install an Adaptor Fitting (Item 19) and Elbow Fitting (Item 20) into each air inlet or the Piston/Drive Disc (Item 2) (See Fig. 4).
3. Using Cap Screws (Item 24), attach the Rotary Air Union Cap (Item 25) to the tapped holes of the Splined Hub (Item 1) (See Fig. 4).

NOTE: The Rotary Air Union Cap air outlets must be aligned at approximately 60° to the Piston/Drive Disc air inlets for proper Hose (Item 22) connection.

4. Tighten the Cap Screws (Item 24) to the recommended torque (See Table 3).
5. Install Hoses (Item 22) (See Fig. 4).
6. Install the Rotary Air Union (Item 21).
7. Connect air supply to the Rotary Air Union.

NOTE: Do not use rigid pipe or tubing for this connection. For fast engagement and disengagement, connect air controls as close to the "DPC" Clutch as possible. Where long air lines are required, use a quick exhaust valve.

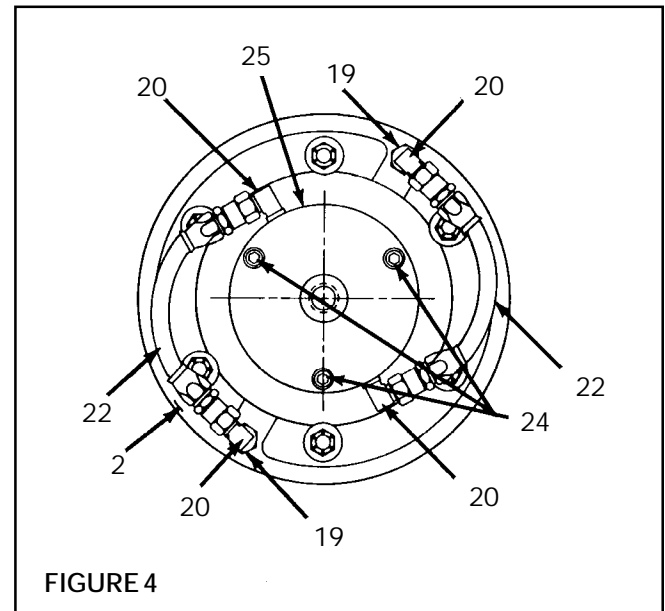

TABLE 3
Recommended Tightening Torques

DESCRIPTION	DPC-9T	DPC-11T
Cap Screw (Item 24)	13 ft. lbs.	13 ft. lbs.

THROUGH SHAFT MOUNTING

1. Drill a 3/8" diameter hole into the center of the shaft; deep enough to reach the desired air outlets (See Fig. 5).

NOTE: Air outlets should be approximately 3/8" from the end of the Hub.

2. Tap the end of the Shaft 5/8–18 by 5/8" deep (See Fig. 5).
3. Drill a 11/32" diameter air outlet hole through the shaft; intersecting the air inlet hole approximately 3/8" from the end of the Hub (See Fig. 5).
4. Tap both air outlet holes 1/8–27 NPT by 5/8" deep (See Fig. 5).
5. Install two Elbow Fittings (Item 20) into each air outlet hole.

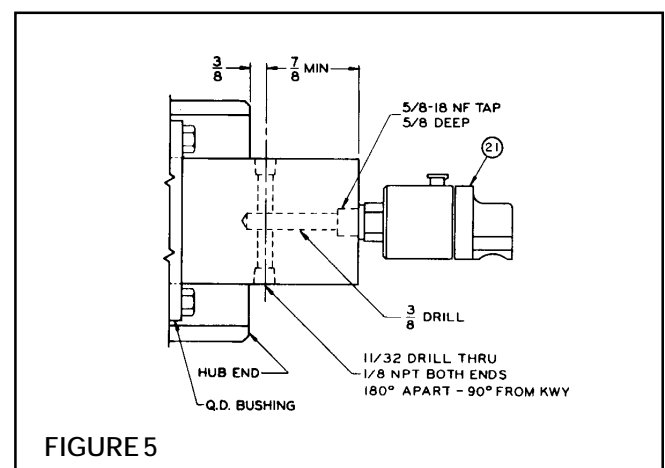

6. Install an Adaptor Fitting (Item 19) and Elbow Fitting (Item 20) into each air inlet of the Piston/Drive Disc (Item 2).
7. Install Hoses (Item 22).
8. Install the Rotary Air Union (Item 21) (See Fig. 5).
9. Connect air supply to the Rotary Air Union.

NOTE: Do not use rigid pipe or tubing for this connection. For fast engagement and disengagement, connect air controls as close to the "DPC" Clutch as possible. Where long air lines are required, use a quick exhaust valve.

THROUGH SHAFT MOUNTING

1. Drill a 3/8" diameter hole into the center of the shaft; deep enough to reach the desired air outlets (See Fig. 5).

NOTE: Air outlets should be approximately 3/8" from the end of the Hub.

2. Tap the end of the Shaft 5/8–18 by 5/8" deep (See Fig. 6).
3. Drill a 11/32" diameter air outlet hole through the shaft; intersecting the air inlet hole approximately 3/8" from the end of the Hub (See Fig. 6).
4. Tap both air outlet holes 1/8–27 NPT by 5/8" deep (See Fig. 6).

5. Install two Elbow Fittings (Item 20) into each air outlet hole.
6. Install an Adaptor Fitting (Item 19) and Elbow Fitting (Item 20) into each air inlet of the Piston/Drive Disc (Item 2).
7. Install Hoses (Item 22).
8. Install the Rotary Air Union (Item 21) (See Fig. 6).
9. Connect air supply to the Rotary Air Union.

NOTE: Do not use rigid pipe or tubing for this connection. For fast engagement and disengagement, connect air controls as close to the "DPC" Clutch as possible. Where long air lines are required, use a quick exhaust valve.

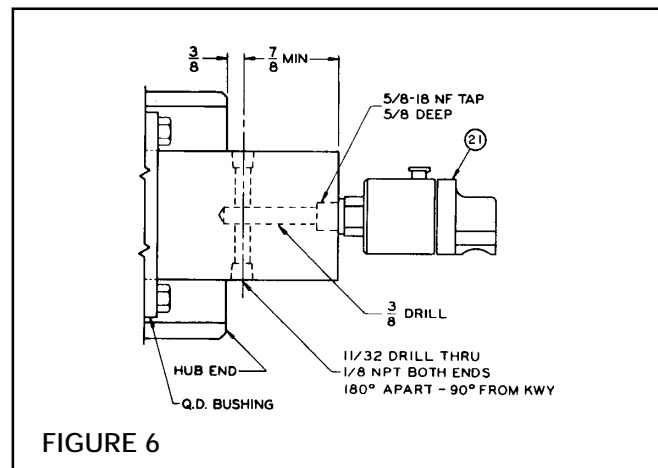

FIGURE 6

LUBRICATION

The most effective and economical way to lubricate the "DPC" Clutch is with an air line lubricator. Available from Nexen, the lubricator injects oil into the pressurized air, forcing a constant oil mist into the air chamber.

Lubricator drip rate is properly set when an oil drop forms in the lubricator sight gauge every twenty cycles of the "DPC" Clutch. Locate the lubricator above and within ten feet of the "DPC" Clutch.

NOTE: Use a low viscosity petroleum base oil, such as SAE10. Synthetic lubricants are not recommended.

For a "DPC" Clutch cycled infrequently, apply two or three drops of oil into the air inlet every two weeks.

OPERATION

CAUTION

Before placing the "DPC" Clutch into service; verify that all screws are secured to the proper torque (See Table 4).

The "DPC" Clutch engages when air pressure is introduced into the Cylinder/Drive Disc. Air pressure pushes the Cylinder/Drive Disc against the Flange Mount Disc, and forces the Cylinder/Drive Disc in the opposite direction. This engages the Friction Facings with the friction surfaces of the Flange Mount Disc and the Friction Disc.

Torque is transmitted through the Cylinder/Drive Disc, and Piston/Drive Disc Splines to the Splined Hub attached to the Shaft with a Q.D. Bushing.

Heat generated at the friction surfaces is dissipated by windage created by the fins on the Flange Mount Disc, and the Friction Disc.

When air is exhausted from the Cylinder, Return Springs pull the Piston to disengaged position.

CAUTION

Never exceed the recommended operating speeds (See Table 5).



WARNING

All parts of the "DPC" Clutch rotate. A guard that will not restrict the flow of cooling air around the "DPC" Clutch must be installed if the "DPC" Clutch is installed in an area where injury to an operator could occur.

TABLE 4

Recommended Tightening Torques

DESCRIPTION	DPC-9T	DPC-11T
Shoulder Screw (Item 12)	9 ft. lbs.	9 ft. lbs.
Cap Screw (Item 15)	48 ft. lbs.	48 ft. lbs.
Cap Screw (Item 24)	13 ft. lbs.	13 ft. lbs.
Cap Screw (Item 28)	48 ft. lbs.	48 ft. lbs.
Pull-Up Bolts	15 ft. lbs.	30 ft. lbs.

TABLE 5

Recommended Tightening Torques

MODEL	OUTER ASSEMBLY	INNER ASSEMBLY
DPC-9T	2200 RPM	3000 RPM
DPC-11T	1800 RPM	2500RPM

PARTS REPLACEMENT

CAUTION

The Nexen "DPC" Clutch has been balanced at the factory. During disassembly, mark components with chalk alignment marks to insure correct alignment, and balance as the "DPC" Clutch is reassembled (See Fig. 7).

When reassembling the Nexen "DPC" Clutch, make sure all screws are tightened to the recommended torque (See Table 6).

TABLE 6

Recommended Tightening Torques

DESCRIPTION	DPC-9T	DPC-11T
Shoulder Screw (Item 12)	9 ft. lbs.	9 ft. lbs.
Cap Screw (Item 15)	48 ft. lbs.	48 ft. lbs.
Cap Screw (Item 24)	13 ft. lbs.	13 ft. lbs.
Cap Screw (Item 28)	48 ft. lbs.	48 ft. lbs.
Pull-Up Bolts	15 ft. lbs.	30 ft. lbs.

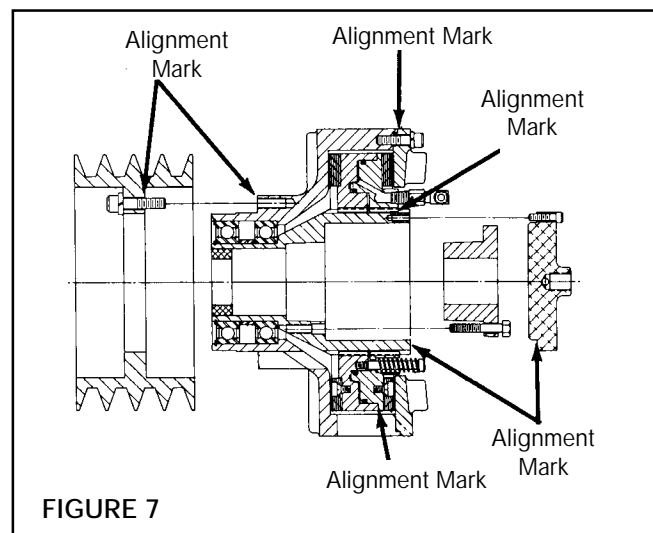

FIGURE 7

FRICION FACING (Item 4)

NOTE: Inspect Friction Facings for wear, and replace when they are appropriately 9/32" thick. Friction Facings can be replaced without removing the "DPC" Clutch from the motor shaft.

1. Disconnect the air supply and Hose Assemblies at the Piston/Drive Disc Elbow Fittings.

NOTE: If the "DPC" Clutch is shaft end mounted; remove the Rotary Air Union Cap (Item 25). On through shaft installation; remove the Elbow Fittings (Item 20) from the shaft.

2. Remove the Cap Screws (Item 15) and Lockwashers (Item 14) (See Fig. 8).
3. Remove the Friction Disc (Item 6) (See Fig. 8).
4. Remove the Shoulder Screws (Item 12) and Springs (Item 13) (See Fig. 8).

5. Slide the Piston/Drive Disc (Item 2) off of the Splined Hub (Item 1) (See Fig. 8).
6. Remove the Retaining Ring (Item 10) (See Fig. 8).

!
WARNING

Special attention should be exercised when working with retaining rings. Always wear safety goggles when working with spring or tension loaded fasteners or devices.

7. Slide the Cylinder/Drive Disc (Item 3) off of the Splined Hub (Item 1) (See Fig. 8).
8. Remove the Machine Screws (Item 11), and replace worn Friction Facings (Item 4) (See Fig. 8).

NOTE: On some models of the "DPC-9T" and "DPC-11T", the Machine Screws (Item 11) are assembled with a green anaerobic thread locking compound. If remove is difficult, strike the end of the screwdriver with a hammer to break the crystalline structure of this locking compound before attempting to remove the screws. The Machine Screws (Item 11) that are furnished with new Friction Facings have a locking patch, and do not require the use of a thread locking compound.

9. Reverse Steps 1 through 7 to reassemble the "DPC" Clutch; noting chalk alignment marks; and tighten all screws to the recommended torque (See Table 6).

O'RINGS (Items 8 & 9)

NOTE: Replace O'rings (Items 8 & 9) if there are noticeable air leaks, or a loss of torque.

1. Proceed with Steps 1 through 7 for the Friction Facing Replacement.
2. Remove O'rings (Items 8 & 9), and clean o-ring contact surfaces with fresh safety solvent (See Fig. 9).
3. Lubricate new O'rings, and o-ring contact surfaces with fresh o-ring lubricant.
4. Install new O'rings (Items 8 & 9) (See Fig. 9).
5. Revers Step 1 to reassemble the "DPC" Clutch; noting chalk alignment marks, and tighten all screws to the recommended torque (See Table 6).

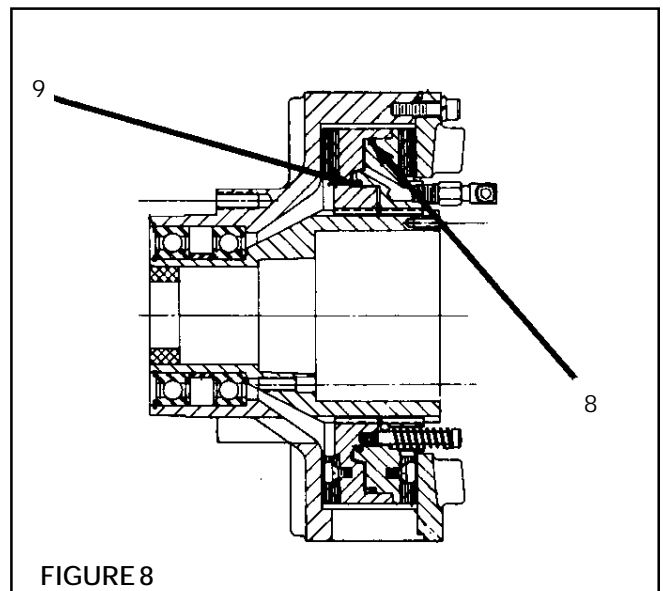
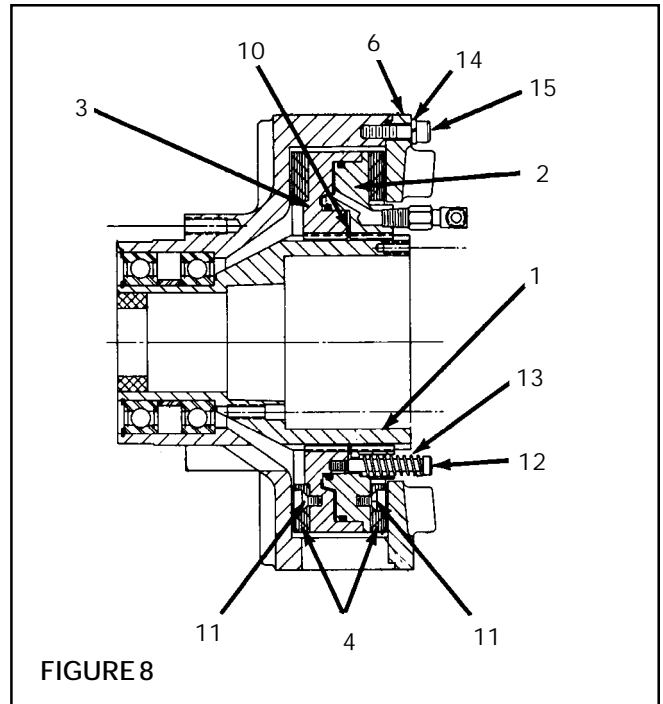

BEARINGS (Item 16)

NOTE: "DPC" Clutch Bearings are prelubricated, sealed, and do not require further lubrication.

1. Disconnect the air supply line, and Hose Assemblies at the Piston/Drive Disc Elbow Fittings.

NOTE: If the "DPC" Clutch is shaft mounted; remove the Rotary Air Union Cap (Item 25). On through shaft installation; remove the Elbow Fittings (Item 20) from the shaft.

2. Loosen the Q.D. Bushing.
 - a. remove Q.D. Bushing Pull-Up Bolts, and Lockwashers.
 - b. Insert Pull-Up Bolts into tapped Q.D. Bushing removal holes, and alternately and evenly tighten each one until the Splined Hub (Item 1) is loose on the Q.D. Bushing.
3. Wedge a screwdriver into the sawcut in the Q.D. Bushing to loosen the Q.D. Bushing from the Shaft; then remove the "DPC" Clutch.
4. Remove Cap Screws (Item 28), and Lockwashers (Item 27), and Sheave (Item 26) in mounted on the "DPC" Clutch (See Fig. 10).
5. Proceed with steps 1 through 7 for the Friction Facing replacement.
6. Remove Retaining Ring (Item 17) (See Fig. 10).



WARNING

Special attention should be exercised when working with retaining rings. Always wear safety goggles when working with spring or tension loaded fasteners or devices.

7. Fully supporting the Housing (Item 5); press the Hub (Item 1), out of the Housing and Bearings. (See Fig. 10).
8. Remove Retaining Ring (Item 18) (See Fig. 10).

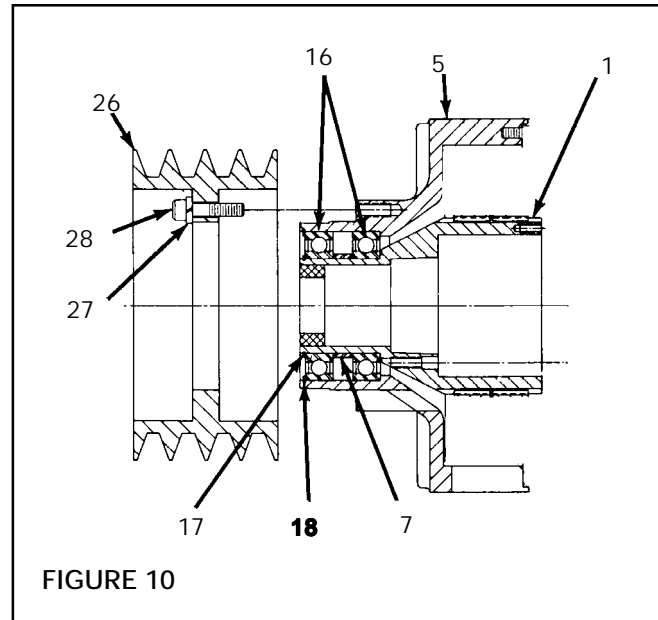

FIGURE 10

9. Fully supporting the Housing (Item 5); push the Bearing (Item 16), and Spacer (Item 17), out of the Housing (See Fig. 10)
10. Clean bearing contact surfaces of both Housing (Item 5), and Hub (Item 1) with fresh safety solvent.
11. Press new Bearings (Item 16), and Spacer (Item 7) into the Housing (Item 5) (See Fig. 10).

NOTE: When installing new Bearings; carefully align the Bearing O.D. with the Housing bore. Apply Loctite® RC 601 or equivalent to the outer race of the new Bearings.

12. Install Retaining Ring (Item 18) (See Fig. 10).
13. Fully supporting the inner race of the new Bearings; press the Hub (Item 1) into the Bearings, and Housing.
14. Install Retaining Ring (Item 17) (See Fig. 10).
15. Reverse Steps 1 through 5 to reassemble the "DPC" Clutch; noting the chalk alignment marks, and tighten all screws to the recommended torque (See Table 6).

REPLACEMENT PARTS

The Item or "Balloon" Number for all Nexen Products is used for part identification on all Product Parts List, Product Price List, Unit Assembly Drawings, Bills of Materials, and Instruction Manuals.

When ordering replacement parts, specify model designation, item number, part description, and quantity. Purchase replacement parts through your local Nexen Distributor.

PARTS LIST

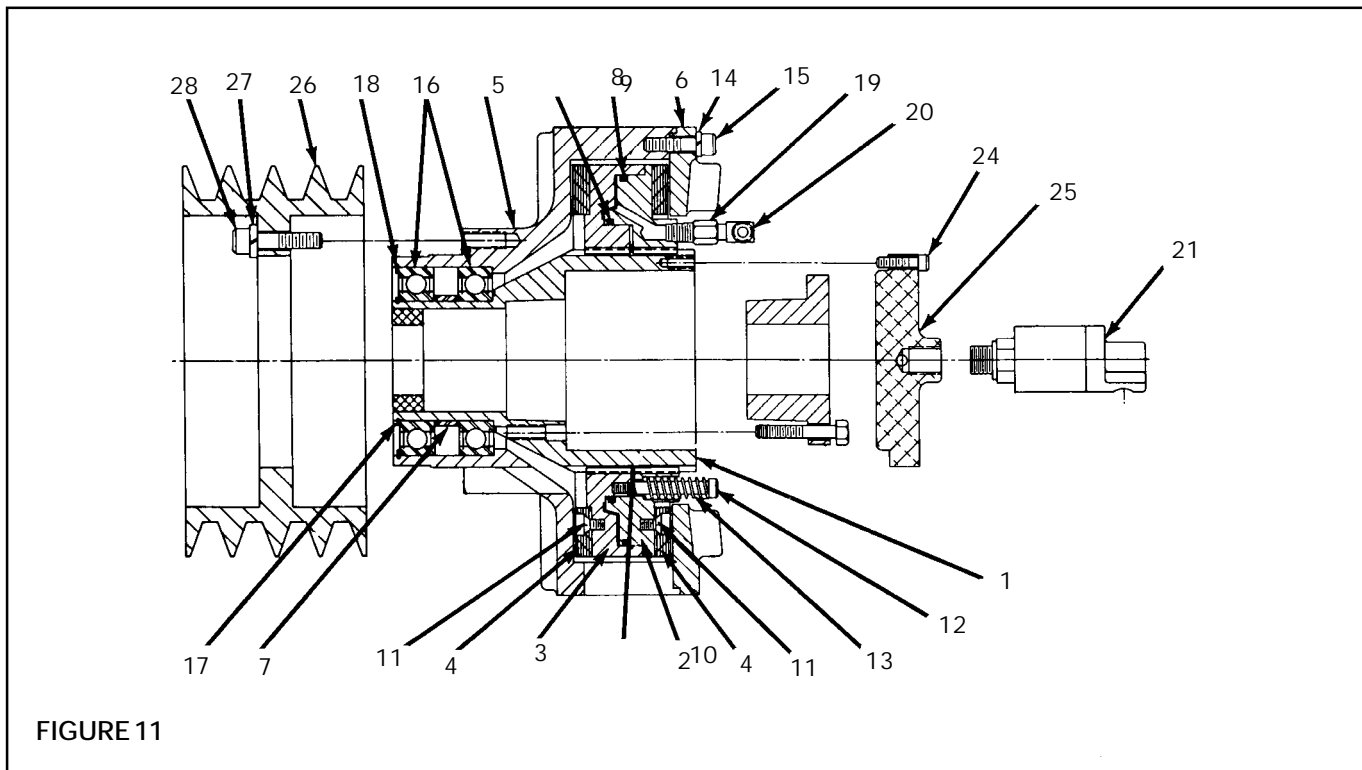

FIGURE 11

CLUTCH ASSEMBLY

ITEM	DESCRIPTION	QTY.
1	Hub	1
2	Piston/Drive Disc	1
3	Cylinder/Drive Disc	1
4	Friction Facing	2
5	Housing	1
6	Friction Disc	1
7	Spacer	1
8	O'ring Seal (Large)	1
9	O'ring Seal (Small)	1
10	Retaining Ring	1
11	Machine Screw	•
12	Shoulder Screw	••
13	Spring	••
14	Lockwasher	6
15	Cap Screw	6
16	Bearing	2
17	Retaining Ring	1
18	Retaining Ring	1
19	Adapter Fitting	2
20	Elbow Fitting	4
21	Rotary Air Union	1
22	Hose Assembly (Not Shown)	2
23	Hose Assembly (Not Shown)	1

MODEL	• QTY	•• QTY
"DPC-9T"	12	4
"DPC-11T"	16	6

ROTARY AIR UNION CAP

ITEM	DESCRIPTION	QTY
24	Rotary Air Union Cap	1
25	Cap Screw	3

SHEAVE

ITEM	DESCRIPTION	QTY
26	Sheave	1
27	Lockwasher	6
28	Cap Screw	6

WARRANTIES

Warranties

Nexen warrants that the Products will be free from any defects in material or workmanship for a period of 12 months from the date of shipment. NEXEN MAKES NO OTHER WARRANTY, EXPRESS OR IMPLIED, AND ALL IMPLIED WARRANTIES, INCLUDING WITHOUT LIMITATION, IMPLIED WARRANTIES OF MERCHANTABILITY AND FITNESS FOR A PARTICULAR PURPOSE ARE HEREBY DISCLAIMED. This warranty applies only if (a) the Product has been installed, used and maintained in accordance with any applicable Nexen installation or maintenance manual for the Product; (b) the alleged defect is not attributable to normal wear and tear; (c) the Product has not been altered, misused or used for purposes other than those for which it was intended; and (d) Buyer has given written notice of the alleged defect to Nexen, and delivered the allegedly defective Product to Nexen, within one year of the date of shipment.

Exclusive Remedy

The exclusive remedy of the Buyer for any breach of the warranties set out above will be, at the sole discretion of Nexen, a repair or replacement with new, serviceably used or reconditioned Product, or issuance of credit in the amount of the purchase price paid to Nexen by the Buyer for the Products.

Limitation of Nexen's Liability

TO THE EXTENT PERMITTED BY LAW NEXEN SHALL HAVE NO LIABILITY TO BUYER OR ANY OTHER PERSON FOR INCIDENTAL DAMAGES, SPECIAL DAMAGES, CONSEQUENTIAL DAMAGES OR OTHER DAMAGES OF ANY KIND OR NATURE WHATSOEVER, WHETHER ARISING OUT OF BREACH OF WARRANTY OR OTHER BREACH OF CONTRACT, NEGLIGENCE OR OTHER TORT, OR OTHERWISE, EVEN IF NEXEN SHALL HAVE BEEN ADVISED OF THE POSSIBILITY OR LIKELIHOOD OF SUCH POTENTIAL LOSS OR DAMAGE. For all of the purposes hereof, the term "consequential damages" shall include lost profits, penalties, delay images, liquidated damages or other damages and liabilities which Buyer shall be obligated to pay or which Buyer may incur based upon, related to or arising out of its contracts with its customers or other third parties. In no event shall Nexen be liable for any amount of damages in excess of amounts paid by Buyer for Products or services as to which a breach of contract has been determined to exist. The parties expressly agree that the price for the Products and the services was determined in consideration of the limitation on damages set forth herein and such limitation has been specifically bargained for and constitutes an agreed allocation of risk which shall survive the determination of any court of competent jurisdiction that any remedy herein fails of its essential purpose.

Limitation of Damages

In no event shall Nexen be liable for any consequential, indirect, incidental, or special damages of any nature whatsoever, including without limitation, lost profits arising from the sale or use of the Products.

Warranty Claim Procedures

To make a claim under this warranty, the claimant must give written notice of the alleged defect to whom the Product was purchased from and deliver the Product to same within one year of the date on which the alleged defect first became apparent.

nexen[®]

Nexen Group, Inc.
560 Oak Grove Parkway
Vadnais Heights, MN 55127

800.843.7445
Fax: 651.286.1099
www.nexengroup.com

ISO 9001 Certified